



## Key features

- Low installation and maintenance costs.
- Weather-proof and UV- proof.
- IP Rating IP66
- High LED performance
- LED's operation life time over 70,000 hours.
- Light dimming engine.
- LED strings shunt protection.
- Battery inside pole.
- Wind- resistant and self cleaning.
- Coated with electrostatic spray for anti-salted, anti-acid, rust resistant.
- Material: die cast aluminum reflector and flat or lenticular tempered glass cover.
- IDA approved .

The SolarPath HIGHLIGHT SP-WSDL™ is the most advanced and sophisticated solar light pole available on the market. The solar light pole is completely off-grid and works autonomously, using sustainable solar power. This means there is no need for expensive cabling and invasive trenching, which results in fast installation, easy operation and a low total cost of ownership. The curved vertically integrated solar panels are wind-resistant and self-cleaning, as dirt and dust cannot stick on the design. Solar energy generated during the day is stored in high-quality lithium batteries, which are long-lasting and require minimum maintenance. The highly-efficient LED-luminaire provides powerful lighting at night.

## Technical Specifications

Solar Module Parameters	Type	CIGS Flexible Module	
	Power	Up to 510W	
Solar Charge Controller Parameters	Type	MPPT	
Battery type and parameters	LifePO4	Up to 150AH	
LED Light Parameters	Light Source Power	Up to 60W	
	Brightness	Up to 7,404 lm	
	CCT (Correlated Color Temperature)	3,000K-6,500K	
Operation profile	Programmable, depend on solar radiation.		
Operation Temperature	26.6°F-113°F		
Pole Height	Up to 25 Ft		

## Uses and Applications Guide

Streets lighting	●
Parking lots	●
Walking/bike path	●
Branch roads	●
Residential roads	●
Public parks	●

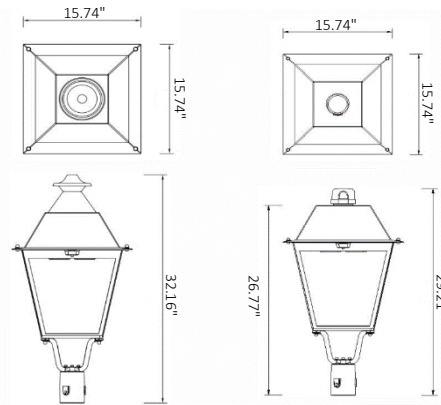

## Ordering Guide: EXAMPLE: HIGHLIGHT SP-WSDL -A-180W-FLA-30W-1-30K—60AH-GR-00

Model	Solar Panel Quantity	Solar Panel	Led Power	Distribution Type	Led Color Temp	Battery capacity	Pole Height	LED Body color	Options
HIGHLIGHT SP-WSDL	A-1 panel	80W	20W	2 – Type II	30K	20AH	12FT	BLK- Black *other colors are available	00 – No motion sensor 01 – With motion sensor
	B-2 panels	105W	30W	5- Type V	40K	40AH	16FT		
	C-3 panels	120W	40W		50K	60AH	20FT		
		170W	50W		65K	100AH	25FT		
			60W			120AH			
						150AH			



\*Up on request

Legal Clarification: All technical information and/or products listings and/or technical support, and/or any kind of graphics, illustrations and/or instructions and/or the names, trade names, trademarks, trade symbols, service marks, logos, icons and trade dress of SolarPath Inc or in connection to SolarPath Inc or any of its selling products, contained herein is in the exclusive ownership of SolarPath Inc and may not be altered and/or used in any manner including but not limited to copy of some or all of the said material by users and/or viewers or any third party for that matter of this document and the website to which it is linked without the express prior written permission of SolarPath Inc. Furthermore, redistribution or any kind of commercial use or alteration or any kind of use other than downloading presented information in some or all contents of downloadable documents, and/or downloadable contents, is strictly prohibited without express written prior permission. All information set out herein is subject to changes as may occur from time to time. SolarPath Inc is not responsible for, and cannot guarantee and shall not be held liable for any information or the accuracy of such in websites that it does not manage